



RFB 2025-04, Addendum No. 1 Rancho Cañada del Oro Stock Pond Restoration Project

To: Request for Bids Recipients
From: Rachel Clemons, Watershed Restoration Specialist
Date: 3/7/2025
Re: Addendum 1 for RFB 2025-04

Summary

During the mandatory pre-bid site visit on 3/4/25, the Authority received the questions listed in this document. Addendum No. 1 consists of answers to these questions and supporting attachments. Question 20 is still in progress and will be answered in the next addendum. The final deadline to submit additional questions not listed in this document is Wednesday March 12 at 4pm.

Additionally, the Authority has made a minor addition to Section 6 of the Bid Proposal Form (Part C of Bid Package), which clarifies the types of projects that shall be listed as relevant experience. Bidders shall now use the revised version of Part C of the Bid Package when submitting their bid. The tracked changes version is shown in this addendum as Attachment 3.

Contents

- Site Visit Attendee List
- Question and Answer List
- Attachment 1 – Map of Regular and Alternative Access Routes
- Attachment 2 – Staff Gauge Information
- Attachment 3 – Revised Bid Forms (Part C of Bid Package, tracked changes version)
- Attachment 4 – Revised Bid Forms (Part C of Bid Package, clean version)

Attendee List

	Company	Location	Contact(s)	Email
1	MidCal Dredging	Riverdale	Randy Thomas Jake Errotabere	randy@midcaldredge.com jake@midcaldredge.com
2	Storesund Construction	San Francisco	Nathan Tackett	greg@rochason.com
3	Hanford ARC	Petaluma	Brandon Huneke Cindy Orme	b.huneke@hanfordarc.com c.orme@hanfordarc.com
4	D-Line Constructors	Oakland	Herb Fry	bids@dlineconstructors.com
5	Brannon Corporation	San Jose	Paul Brannon Howard Jones	paulb@brannondemo.com howard@brannondemo.com
6	Gradetech, Inc.	Livermore	Greg Fulton	greggradetech@outlook.com
7	Graniterock	San Jose	Juan D. Alvarado	estimating@graniterock.com
8	Irish Excavation	Morgan Hill	Sean O'Donoghue	sean@irishexcavation.com
9	ETIC Engineering	Pleasant Hill	Claire Walker Boris Portillo	cwalker@eticeng.com bportillo@eticeng.com
10	Triangle Land Restoration	Sacramento	Michael Peterson	mpeterson@teichert.com

Question and Answer

General Project Information

1. What is the expected construction window for the project?

The project is estimated to last approximately 60-90 days. Work will begin in early June and must be substantially complete by mid-September.

2. What is the Engineer's cost estimate and when was the estimate created?

The most recent Engineer's opinion of probable costs was generated in November 2024 and is \$620,000.

3. Does the Engineer's estimate assume limited water access or weight limitations?

No, the estimate is preliminary and did not address these items. (See Questions 7, 8, 16)

4. Does the contractor need to obtain any permits or put any permits in their name?

No. The Authority has procured all the necessary permits for the project. If any permits are needed for municipal water use or vehicles/equipment on public roads, that is the Contractor's responsibility.

5. What does the contractor need to know about working around endangered species and/or potential historic or cultural resources during the project?

The Authority will provide a biological monitor for the project. The monitor will be needed during the dewatering work at Pond RC-01 to capture, relocate, and otherwise protect the existing population of western pond turtles, or other endangered species (such as the California red-legged frog) that are less likely to be encountered. The Authority will also provide an archaeologist and tribal monitor, who will be present during any digging or ground disturbing activities at Pond RC-01. The biological monitor or cultural monitors may direct the Contractor to stop work, in which case pricing for "stand down" time from the bid will be utilized to offset the delay in the project. All of the Contractor's staff will also receive training from the monitors to recognize endangered species or potential archaeological materials on the project site, and to alert the monitors and the Authority of their presence. See Exhibit 2 of the bid package for more information (Table 1(a) for endangered species protection; Table 1(c) for cultural resource protection).

6. Would the Authority consider authorizing Saturday work? If so, would the Authority pay for the additional biological and/or cultural monitoring?

The Authority would consider authorizing Saturday work but would not consider a change order for overtime because of contractor-caused delays. The broad construction window for the project is sufficient to complete the project on weekdays. If Saturday work is authorized, the Authority would pay for the biological and/or cultural monitor to work overtime on Saturdays as needed.

SITE ACCESS

7. Is there a weight limit to access the site?

Casa Loma Road has a bridge prior to accessing the Preserve (GPS point = 37.1483,-121.7723, Bridge No. 37C0522). The Authority does not own or manage this bridge. On 3/7/25, the Authority inquired about weight restrictions on this bridge with the Santa Clara County Roads and Airports Department, and their response did not indicate a weight limit. It is the Contractor's responsibility to verify and follow all height/width and weight restrictions on public roads while accessing the site. There are no weight limitations for equipment within the Preserve.

8. Can the Contractor access the site from via the Uvas Road entrance to Rancho Cañada del Oro Open Space Preserve?

Yes. The alternative access route is from County Road G8/Uvas Road (see Attachment 1). This unnamed ranch road on Authority-owned property is ~2.4 miles long and connects to Twin Creeks Road, between RC-07 and RC-10. The road is steep and narrow; long trailers, "low boys", or other lengthy pieces of equipment cannot make the tight turns. However, excavators, short-end dumps, or other small equipment can and have used the road. The Authority will permit the Contractor to track equipment up the road, and to restore the road to its prior condition or use rubber-tracked equipment. It is the Contractor's responsibility to verify their equipment can safely use the road. At the top of the road near its convergence with Twin Creeks Road, there is a very tight turn due to cattle fencing. The Authority can remove/reinstall the fencing in coordination with the Contractor to allow equipment access. The Contractor may conduct minor vegetation trimming and removal along the alternate access road as necessary.

9. Will the Authority provide combination locks on the gates?

Yes, the Authority will install combination locks on all gates that the Contractor needs to use.

10. Is the contractor required to move equipment away from the ponds at the end of each day?

No. The contractor must follow all BMPs for handling fuels and preventing spills but is not otherwise required to track equipment up and down the roads.

11. Is it the Contractor's responsibility to grade or improve the lowest road segment down to Pond RC-01 (approximately 300 feet)?

Yes. The Contractor is responsible for grading and any other road improvements necessary for equipment access at Pond RC-01 and/or Pond RC-10. Pond RC-07 is directly adjacent to Twin Creeks Road.

12. Must the Contractor restore the lowest road segment down to pond RC-01 to its previous condition?

The road must be left in a stable condition with the widest possible access preserved.

Pond RC-01 Dewatering

13. Can the contractor use a different pump to drain RC-01 than specified in the bid package?

The Contractor may propose a different pump through a submittal to be reviewed by The Authority and its Engineer(s). High velocity pumps may require additional erosion control or resource protection measures to dissipate high energy outflows and to avoid entrainment of wildlife on the intake.

14. Are there turbidity requirements for the discharge from dewatering Pond RC-01?

The project's 401 Certification/Waste Discharge Permit from the Regional Water Board does not specify a turbidity threshold for dewatering. The permit does require that the Contractor's methods have the minimum necessary impacts to the receiving waters and do not cause sedimentation or erosion downstream of the work area. The dewatering detail on plan sheet C-2.1 requires placement of rock and a geotextile fabric at the discharge point, which will help capture fine sediment. See plan sheet C-2.1, plan sheet C-9.0 (Note 5), and Exhibit 2 (Table 1(b), Conditions 4-6 and Condition 13) for more information.

15. How much water is estimated to be in RC-01? How long is it expected to take to dewater RC-01?

At its full capacity, the pond holds approximately 400,000 cubic feet of water, and the pump specified in the Construction Drawings is estimated to require at least 40 hours of pumping. Contractor is responsible for pumping the pond dry in sufficient time prior to construction.

Grading and Excavation

16. Are there water sources on the property for dust suppression and grading?

No. The water sources used for grazing within the preserve are limited and dependent on rainfall. It is the responsibility of the Contractor to estimate and procure needed water. The Contractor could temporarily store and reuse water pumped from RC-01, or bring a filled water truck/container on site.

17. The bid package describes using 'suitable material' for the pond work. How does the contractor determine what suitable material is? Who determines if the compaction of soils in the pond is sufficient?

Section 7.2.2 of the Geotechnical Report (Exhibit 5 of the Bid Package) addresses the use of on-site soils and soil compaction. The project's Geotechnical Engineer, Butano Geotechnical, is a subconsultant to the prime Engineer, Sherwood Design Engineers. Butano will be available to conduct as-needed site visits and inspections. Butano can assist in verifying suitable fill material in the field.

18. What is the purpose of the “borrow area” next to Pond RC-07?

The borrow area is to be used for grading/fill at Pond RC-07 and/or Pond RC-10 in the event that the material excavated from the pond(s) is not suitable for reuse.

19. Who is responsible for surveying and staking the project?

The Contractor is responsible for surveying and staking areas of grading. The Engineer will provide a CAD file to the Contractor’s chosen surveyor to use in the creation of a staking layout.

20. Is the Contractor responsible for repairing the existing berm failure on RC-07?

The Authority is currently coordinating with its Engineers and will answer this question in the next addendum.

21. Will the outlet pipe on RC-07 be buried or at grade?

The pipe will be installed through the berm by excavation and will then be at grade until its discharge point.

22. Does the Contractor need to remove all the fence at RC-07, or only the portions needed to conduct the work?

The Contractor must remove only the portions of fencing necessary to perform the work. All other fencing can remain as is. The Contractor shall replace all removed fencing with in-kind, per the Construction Drawings.

23. Who is responsible for directing the disposal of the excavated soil and/or organic materials from RC-07 and RC-10? Where will materials be placed?

The Authority and its Engineer(s) will direct the Contractor to dispose of all materials on site, at a nearby flat location.

Other

24. Is there a detail for the staff gages to be installed?

A detail is not included in the Construction Drawings, but further information has been provided in Attachment 2 to this Addendum.

25. Does the Authority enforce CARB-compliant (California Air Resources Board) equipment on its projects?

The Authority is not a regulatory agency. It is the responsibility of the Contractor to ensure they follow all State and Local air quality regulations.

<https://ww2.arb.ca.gov/our-work/topics/construction-earthmoving-equipment>

Rancho Pond Restoration

37 views
Last edit was seconds ago

Add layer Share Preview

STAGING AREAS
Individual styles

- 1
- 2
- 3

PONDS
Individual styles

- 📍 RC-01
- 📍 RC-07
- 📍 RC-10

Access Routes
Individual styles

- 📍 Alternative Access
- 📍 Alternative Entrance
- 📍 Regular Access (Casa Loma ...)
- 📍 Twin Creeks Rd (Pond Access)

FENCING

Impact Areas

Base map

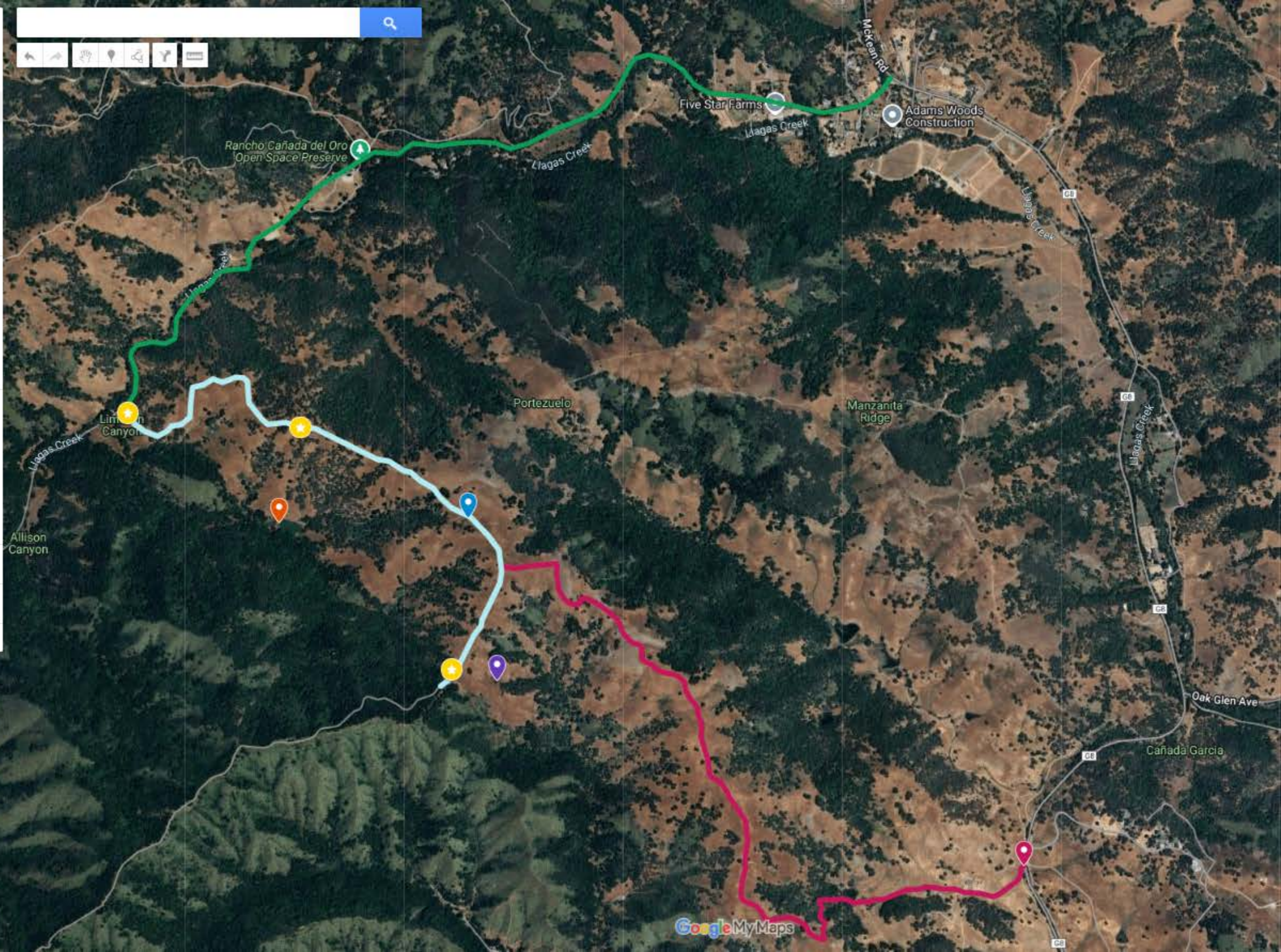

Rancho Cañada del Oro Stock Pond Restoration Project

Staff Gage Detail

One staff gage will be placed in each of the three ponds, per the Construction Drawings. Porcelain-enameled iron staff gage, Stevens Water Monitoring Systems, Inc. Style C or equivalent. Exact model numbers to be determined by the Authority.

Gages at RC-07 and RC-10 should be installed with three T-posts surrounding them, as shown in the photo below, in order to protect them from cattle damage. Typical installation detail is shown on the following page. Contractor will coordinate with the Authority on exact placement such that the top of the gage exceeds the outlet elevation by approximately one foot.



LENGTH MAY VARY PER POND

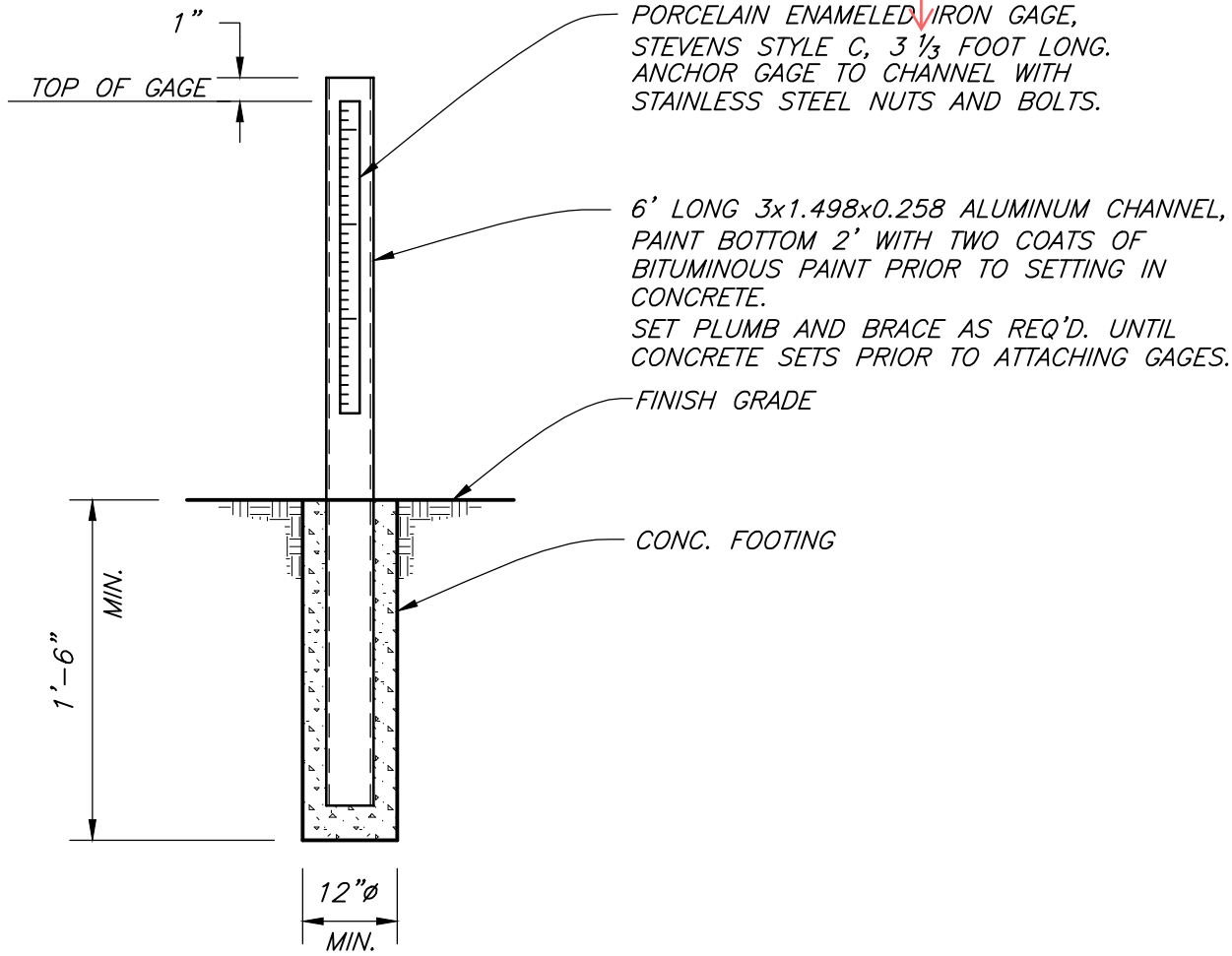

STAFF GAGE ASSEMBLY DETAIL

NOT TO SCALE

2
—

TYPICAL STAFF GAGE DESIGN

Porcelain Enamelled Staff Gages

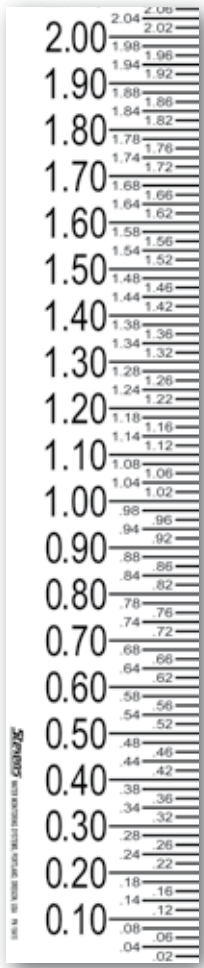

Style A

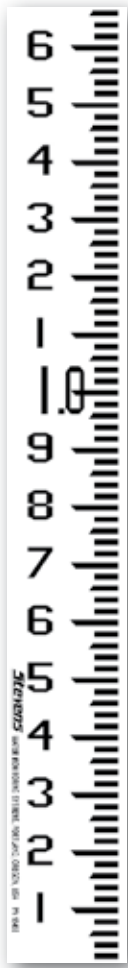

Style C



Style I

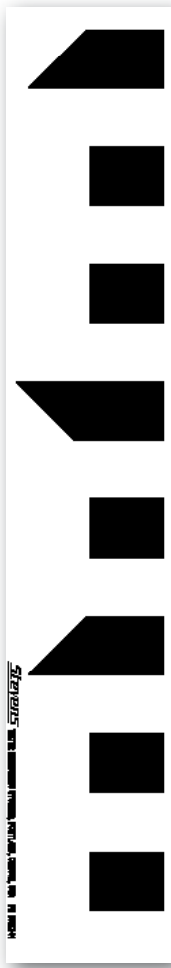

Style E



Style M

Description

The Staff Gage has a long history of visually providing a direct indicator for determining water level. The gages are designed with heavy metal grommets with a 0.2 inch opening for easy mounting to a wall or pier.

The gage consists of a metal plate with accurately positioned markings. The metal plates are heavy 16 gage (0.075 in / 1.9 mm) enameled iron or steel, which is completely covered with a baked-on porcelain enamel finish to resist rust or discoloration. Different colors of enamel are used to provide the markings; typically black numbers on a white background.

Stevens designs and provides custom staff gages for applications requiring larger displays, unique mounting angles, slopes or visual flow measurements.

www.stevenswater.com

1.800.452.5272

Features

- Time-proven basic visual reference of water level measurement
- Easy to see and read
- Available in many standard sizes (english or metric)
- Custom scales, sizes and colors available
- Pre-numbered or “build your own” options
- Rugged and durable weather resistant design

Applications

- Rivers, lakes, streams, dams and reservoirs
- Wastewater treatment plants
- Flumes and weirs
- Visual flow measurement

Stevens[®]
Water Monitoring Systems, Inc.

Porcelain Enameled Staff Gage Styles

Style A

The Style A staff gage is 4 inches wide and comes in 3.33 ft. sections. The standard maximum height is 13.33 feet. The Style A has graduated marks every ft., 1/10th ft., and 0.02 ft. with total elevations.

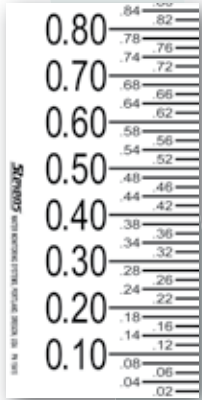

Part Number	Range
15415	0 to 3.33 feet
15395	3.33 to 6.66 feet
15396	6.66 to 10.0 feet
15397	10.0 to 13.33 feet

Style C

The Style C staff gage is 2.5 inches wide and is available in separate lengths of 0 - 1.06 feet., 0 - 1.56 feet, 0 - 1.56 feet, 0 - 2.06 feet, 0 - 3.06 feet, 0 - 4.06 feet, and 3.06 - 5.06 feet. Style C also comes in standard 3.33 ft. sections for a maximum height of of 20 feet. Style C has graduations every 100th of a foot with numerical marks every ft. and every tenth of a ft.



Part Number	Range	Part Number	Range
15402	0 to 1.06 ft.	15405	0 to 3.33 ft.
15403	0 to 1.56 ft.	15406	3.33 to 6.66 ft.
15404	0 2.06 ft.	15407	6.66 to 10.00 ft.
15418	0 to 3.06 ft.	15408	10.00 to 13.33 ft.
15419	3.06 to 5.06 ft.	15409	13.33 to 16.66 ft.
43082	0 to 4.06 ft.	15410	16.66 to 20.0 ft.

Style I

The Style I staff gage is 2.5 inches wide and has graduation every 0.25 inches with numerical marks every inch. Style I is available in any length ranging from 0 to 48 inches.



Part Number	Range
90223	0 to 14.0 inches
44405	0 to 18.0 inches
44406	0 to 24.0 inches
45637	0 to 36.0 inches
45480	0 to 48.0 inches

Style E

The Style E is an English measurement staff gage that is 3.5 inches wide and is available in 1, 2 or 5 ft. sections. Style E is graduated in feet every tenth of a ft. Separate figure plates (see below) can be fastened on a pier, wall or other surface next to the Style E staff gage to number any desired elevation.

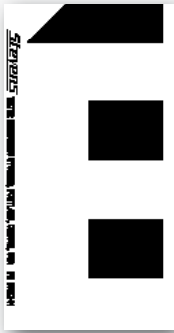

Part Number	Range
15420	1 foot section
15421	2 foot section
15422	5 foot section

Style M

The Style M is a metric measurement staff gage that is 65 mm wide and is available in 1 meter sections. The Style M is divided into centimeters with each decimeter numbered. Separate figure plates (see below) can be fastened on a pier, wall or other surface next to the Style M staff gage to number any desired elevation.



Part Number	Range
15423	1 meter section

Figure Plates

Separate numerical figure plates are available in 2" x 3", 3" x 4" and 4" x 6" sizes. Figure plates are commonly used with Style E or Style M staff gages and are fastened to a pier or wall to mark custom elevations.



Figure Plate Number	Figure Plate Dimensions 2" x 3"	Figure Plate Dimensions 3" x 4"	Figure Plate Dimensions 4" x 6"
#0	15424	90980	28134
#1	15425	90981	28135
#2	15426	90982	28136
#3	15427	90983	28137
#4	15428	90984	28138
#5	15429	90985	28139
#6	15430	90986	28140
#7	15431	90987	28141
#8	15432	90988	28142
#9	15430	90986	28140
Minus figure (-)	24187	-	-

Corporate Headquarters

12067 NE Glenn Widing Drive
Suite 106
Portland, Oregon 97220

800.452.5272 Tel

503.445.8000

503.445.8001 Fax

info@stevenswater.com

www.stevenswater.com

Since 1911, Stevens Water Monitoring Systems, Inc. has been a leading manufacturer of:

- Water Level Sensors
- Water Quality Sensors
- Soil Moisture Sensors
- Chart Recorders
- Staff Gages
- Telemetry Systems
- Data Collection Platforms

Porcelain Enameled Staff Gage DATA SHEET

Custom Gages

Stevens is one of the leading providers of custom staff gages. Staff gages can be designed for applications requiring large displays, slopes, or other unique mounting angles that a site may need for easy visual measurements. Numbers and graduated markings on the gage can also be customized to present a clear, visual measurement of water flow.



Custom Stevens staff gage mounted on a sloped pier on the Willamette River in Portland, Oregon. The submarine pictured is the USS Blueback.

C. BID FORMS

(Page left intentionally blank)

C.1 BID PROPOSAL FORM

(To be executed by Bidder and Submitted)

Project Name: Rancho Cañada del Oro Stock Pond Restoration Project

Location: Rancho Cañada del Oro Open Space Preserve
Casa Loma Road at Twin Creeks Road
Santa Clara County, CA

Scope of Work: General Conditions, Supplemental Conditions, mobilization/
demobilization, temporary control, earthwork, and site work as fully
described in the Bid Package for excavation, berm repair, inflow/outflow
pipe installation, and fence installation for three stock ponds at Rancho
Cañada del Oro Open Space Preserve.

Authority Representative: Rachel Clemons, Watershed Restoration Specialist
Santa Clara Valley Open Space Authority
33 Las Colinas Lane
San José, CA 95119
(408) 224-7476

The undersigned has carefully examined the site conditions for the Work, received the required Pre-Bid Meeting materials, reviewed all documents in the Bid Package, including the Plans and Specifications, accepts all terms and conditions of the Agreement, and has reviewed the following Addenda (fill in blanks below as appropriate to the number of Addenda issued for the project):

Addendum No. _____, dated _____, 20____,

Addendum No. _____, dated _____, 20____,

Addendum No. _____, dated _____, 20____.

1. BASE BID

Bid Proposal will be evaluated and awarded based on **Total Base Bid**. The Authority may opt to award additional work, or accept deductive alternates based on unit pricing or breakdown submitted herein. Bidders proposed Duration for Completion shall be for Total Base Bid.

Provide all labor, equipment, material, transportation, applicable tax, profit, insurance, bonds and overhead to perform the Work in accordance with the Project Plans and Technical Specifications. All items are Furnish and Install unless noted otherwise. Refer to Plans and Technical Specifications for more information.						
No.	Description	Reference	Unit Type	Unit Price	Unit Qty	Extension
1	General conditions/mobilization	General Conditions	--	--	--	
2	Supplemental conditions, including water quality and pathogen control requirements	Supplemental Conditions	--	--	--	
Pond RC-01						
3	3(a) Dewatering	Plans	Hour			
	3(b) Pond liner		Cubic yard			
	3(c) On-site soil disposal		Cubic yard			
	3(d) Turtle ramps (2)		Each			
	3(e) Staff gage (1)		Each			
Pond RC-07						
4	4(a) Grading/excavation	Plans	Cubic yard			
	4(b) On-site soil disposal		Cubic yard			
	4(c) Inlet/outlet pipes and rock armor		--	--	--	
	4(d) Staff gage (1)		Each			
Pond RC-10						
5	5(a) Grading/excavation	Plans	Cubic yard			
	5(b) On-site soil disposal		Cubic yard			
	5(c) Outlet pipe and rock armor		--	--	--	
	5(d) Turtle ramp (1)		Each			
	5(e) Staff gage (1)		Each			
6	Post-construction erosion control and seed broadcasting	Plans	--	--	--	
7	Stand down allowance	Plans	--	--	--	\$5,000
TOTAL BASE BID						
Proposed start date – pre-construction work: _____						
Proposed start date – on-site construction work: _____						
Total days to complete project: _____ Calendar Days						

2. UNIT PRICES

Unit Prices shall be used for delays incurred to the project due to special species conditions, and may be exercised at any time during the execution of the Work. Stand-down time eligible for reimbursement shall comply with Supplemental Conditions Article Four, paragraph J. Stand-Down Time.

No.	Description	Unit	Unit Price
U1	Stand-Down Time – Equipment Operator	Hour	\$
U2	Stand-Down Time – Forman	Hour	\$
U3	Stand-Down Time – Laborer	Hour	\$

3. ADDITIVE ALTERNATES

No.	Description	Reference	Add Amount
A1	Pond RC-07 existing fence removal	Construction Plans	
A2	Pond RC-01 fence/gate installation		
A3	Pond RC-07 fence/gate installation		
A4	Pond RC-10 fence/gate installation		

4. CURRENT WORKLOAD AND FINANCIAL CAPACITY.

Contractor must provide adequate current workload and financial information to confirm Contractor’s financial ability to deliver this project.

**(a)WORKLOAD – List ALL current Projects & Value of the Current Work Backlog:
(Attach additional pages if necessary)**

Project	Value of Unfinished Work	Percentage Complete

(b) FINANCIAL – List Contractors’ Company yearly gross revenue for the last three years:

i) List the Company’s yearly gross revenue for the past 3 years.

2022 _____ 2023 _____ 2024 _____

ii) List the Company’s net income for the past 3 years.

2022 _____ 2023 _____ 2024 _____

iii) List the Company’s amount of re-invested income for the past 3 years.

2022 _____ 2023 _____ 2024 _____

5. LITIGATION.

If additional space is needed for explanations, please attach additional pages as necessary.

a) Has your company been assessed liquidated damages within the past 5 years?

No _____ Yes _____

If Yes,
Where? _____
Why? _____

b) Has your company been terminated for default or cause within the past 5 years?

No _____ Yes _____

If Yes,
Where? _____
Why? _____

c) Are there any judgements, claims, arbitration proceedings, or suits pending or outstanding against your organization?

No _____ Yes _____

If Yes,
Where? _____
Why? _____

d) Has your organization filed any lawsuits, submitted claims, or been involved in any litigation with regard to your contract activity within the last five years

No _____ Yes _____

If Yes,
Where? _____

Why? _____

6. **EXPERIENCE.** List three recently (within last 5 years) completed jobs of comparable scope, the contract amount, names, and telephone numbers of contract officers. Use additional sheets as necessary. The selected projects must cumulatively demonstrate the Bidder's experience in pond restoration (grading, liner install, inlet/outlet pipe install, and/or erosion control) and working in job site(s) with sensitive/listed species.

Job/Project Name _____

Owner _____ Year _____ Contract Amt \$ _____

Contact _____ Phone _____

Project Description _____

Job/Project Name _____

Owner _____ Year _____ Contract Amt \$ _____

Contact _____ Phone _____

Project Description _____

Job/Project Name _____

Owner _____ Year _____ Contract Amt \$ _____

Contact _____ Phone _____

Project Description _____

-
5. **NONCOLLUSION CERTIFICATION.** The undersigned has executed and hereby submits the Noncollusion Affidavit (Form C.3), in accordance with Public Contracts Code Section 7106.
6. **BID GUARANTEE.** No Bid will be considered unless accompanied by a guarantee in the amount of ten percent (10%) of the Total Base Bid), which shall be either a **BID BOND** (Attachment 4) written by an admitted surety satisfactory to the Authority in its sole discretion, a certified or cashier's check made payable to the Authority, or a cash deposit. In the event a successful bidder fails to satisfy all conditions for accepting the award (i.e. executed Agreement, provision of required bonds and proof of insurance) within the stated time limits, the Authority may declare the bidder's Bid Guarantee in default. Bidder acknowledges that the amount of actual damages the Authority would suffer in such event is extremely difficult and impractical to determine at this time by reason of the uncertainties, lapse of time, expense and loss of likely bidders resulting from the probable need to re-advertise and call for new bids. Bidder agrees that the amount of such Bid Guarantee shall be kept by the Authority as liquidated damages and agrees that the Authority may then award the work to any other bidder or may call for new bids. All Bid Guarantees will be held until after an award is made, an Agreement entered into, and required bonds and proof of insurance provided, at which time they will be returned.

7. **DISCLOSURE.** The names of all persons financially interested in this Bid Proposal are as follows:

Bidder, or any partner of Bidder, is a corporation, provide the legal name of the corporation, the state of its incorporation and the name and address of the President and of the Secretary. If Bidder is a partnership, provide name of the firm and names and addresses of all individual co-partners. Use additional sheets as necessary. If Bidder is an individual, provide the first and last name and address.

Name of Corporation: _____

State of Incorporation: _____

Name of Officer/Shareholder Title Address

Name of Bidder(s)/Partner(s) (If not a corporation)

8. **WITHDRAWAL OF BIDS.** Bids may be withdrawn prior to the opening of bids only by a signed, written notice received by the Authority Representative prior to the commencement of the bid opening. In consideration of Authority's reliance on and consideration of this Bid Proposal, the undersigned agrees that such Bid Proposal shall be irrevocable upon opening and shall not be withdrawn for sixty (60) calendar days following the bid opening even though award may be made to another bidder. Thereafter, such bid shall be automatically relieved.

I make the above Bid and declare under penalty of perjury that the statements made in this Bid Proposal are true and correct.

FULLY EXECUTED at _____,
City State

on _____,
Month Day Year

Signature¹ _____ Title _____

Name (please type or print) _____

Federal Employer I.D. Number _____

License Type _____

License Number _____ Expiration Date _____

DIR Registration Number _____

Name of Firm _____

Mailing Address _____

City _____ State _____ Zip _____

Phone (Bus) _____ Phone (Cell) _____

Email _____

¹ An authorized person for the Bidder must sign this Bid Proposal. If the Bidder is a partnership, a general partner must sign. If the Bidder is a corporation, an authorized officer of the corporation must sign and a corporate resolution conferring such authority must be provided.

C.2 LIST OF SUBCONTRACTORS
(To be executed by Bidder and Submitted with Bid)

Contractor must set forth the name, address, phone number, type and cost of work, and proof of required license for each subcontractor who will perform work or render services in any amount exceeding one-half percent (1/2%) of the total bid according to provisions of the California Public Contract Code §4100 through §4113. Each subcontractor must be licensed by the State of California Department of Consumer Affairs for the portion of work they perform in accordance with Contractor's License Law. Please attach as many sheets as necessary.

Company Name:

Contact:

Address:

Phone Number:

Type of Work:

Cost of Work:

Required License:

DIR Registration Number:

Company Name:

Contact:

Address:

Phone Number:

Type of Work:

Cost of Work:

Required License:

DIR Registration Number:

Company Name:

Contact:

Address:

Phone Number:

Type of Work:

Cost of Work:

Required License:

DIR Registration Number:

C.3 NONCOLLUSION AFFIDAVIT

NONCOLLUSION DECLARATION TO BE EXECUTED BY BIDDER AND SUBMITTED WITH BID

The undersigned declares:

I am the _____ of _____, the party making the foregoing bid.

The bid is not made in the interest of, or on behalf of, any undisclosed person, partnership, company, association, organization, or corporation. The bid is genuine and not collusive or sham. The bidder has not directly or indirectly induced or solicited any other bidder to put in a false or sham bid. The bidder has not directly or indirectly colluded, conspired, connived, or agreed with any bidder or anyone else to put in a sham bid, or to refrain from bidding. The bidder has not in any manner, directly or indirectly, sought by agreement, communication, or conference with anyone to fix the bid price of the bidder or any other bidder, or to fix any overhead, profit, or cost element of the bid price, or of that of any other bidder. All statements contained in the bid are true. The bidder has not, directly or indirectly, submitted his or her bid price or any breakdown thereof, or the contents thereof, or divulged information or data relative thereto, to any corporation, partnership, company association, organization, bid depository, or to any member or agent thereof to effectuate a collusive or sham bid, and has not paid, and will not pay, any person or entity for such purpose.

Any person executing this declaration on behalf of a bidder that is a corporation, partnership, joint venture, limited liability company, limited liability partnership, or any other entity, hereby represents that he or she has full power to execute, and does execute, this declaration on behalf of the bidder.

I declare under penalty of perjury under the laws of the State of California that the foregoing is true and correct and that this declaration is executed on _____, at _____, California.

(Page left intentionally blank)

C.4 BID BOND

(Note: Bidder must use this form if Bid Guarantee is a Bond)

KNOW ALL PERSONS BY THESE PRESENTS THAT [name of Bidder] (hereinafter Principal), as Principal, and [name of Surety], a corporation organized and doing business under and by virtue of the laws of the State of _____ and duly licensed for the purpose of making, guarantying or becoming sole surety upon bonds or undertakings required or authorized by the laws of the State of California, as Surety, are held and firmly bound unto the Santa Clara Valley Open Space Authority, a California Special Authority, (hereinafter called the Obligee) in the just and full sum of _____ Dollars (\$ _____) _____ lawful money of the United States of America, for the payment of which we hereby bind ourselves and each of our successors and assigns, jointly and severally, firmly by these presents.

THE CONDITION OF THIS OBLIGATION IS SUCH THAT, WHEREAS, the Principal is about to hand in to the Obligee a Bid for the project known as the Rancho Cañada del Oro Stock Pond Restoration Project in accordance with the Contract Documents filed in the office of the Obligee and under the notice inviting proposals therefor.

NOW, THEREFORE, if the Bid as submitted by said Principal shall be accepted, and the contract for such work or supplies be awarded to the Principal, and the said Principal shall fail, neglect or refuse to enter into a contract to perform said work or deliver said supplies, and furnish good and sufficient bond and proof of insurance therefore, then the amount of this bond shall be declared to be forfeited to the Obligee, Santa Clara Valley Open Space Authority.

IN WITNESS WHEREOF, Principal and Surety have caused these presents to be duly signed and sealed this _____ day of _____, 2025.

Signature of Principal Signature of Surety

Attorney-in-Fact
State of California,

County of _____)

On _____ before me, _____
(insert name and title of the officer)

personally appeared _____ who proved to me on the basis of satisfactory evidence to be the person(s) whose name(s) is/are subscribed to the within instrument and acknowledged to me that he/she/they executed the same in his/her/their authorized capacity(ies), and that by his/her/their signature(s) on the instrument the person(s), or the entity upon behalf of which the person(s) acted, executed the instrument.

I certify under PENALTY OF PERJURY under the laws of the State of California that the foregoing paragraph is true and correct.

WITNESS my hand and official seal.

Signature

Seal

(Page left intentionally blank)

C.5 PROOF OF PUBLIC WORKS CONTRACTOR REGISTRATION

Attach proof of Contractor and subcontractors' current and valid Department of Industrial Relations Public Works Contractor Registration (Lab. Code § 1725.5)

(Page left intentionally blank.)

C. BID FORMS

(Page left intentionally blank)

C.1 BID PROPOSAL FORM

(To be executed by Bidder and Submitted)

Project Name: Rancho Cañada del Oro Stock Pond Restoration Project

Location: Rancho Cañada del Oro Open Space Preserve
Casa Loma Road at Twin Creeks Road
Santa Clara County, CA

Scope of Work: General Conditions, Supplemental Conditions, mobilization/
demobilization, temporary control, earthwork, and site work as fully
described in the Bid Package for excavation, berm repair, inflow/outflow
pipe installation, and fence installation for three stock ponds at Rancho
Cañada del Oro Open Space Preserve.

Authority Representative: Rachel Clemons, Watershed Restoration Specialist
Santa Clara Valley Open Space Authority
33 Las Colinas Lane
San José, CA 95119
(408) 224-7476

The undersigned has carefully examined the site conditions for the Work, received the required Pre-Bid Meeting materials, reviewed all documents in the Bid Package, including the Plans and Specifications, accepts all terms and conditions of the Agreement, and has reviewed the following Addenda (fill in blanks below as appropriate to the number of Addenda issued for the project):

Addendum No. _____, dated _____, 20_____,
Addendum No. _____, dated _____, 20_____,
Addendum No. _____, dated _____, 20_____.

1. BASE BID

Bid Proposal will be evaluated and awarded based on **Total Base Bid**. The Authority may opt to award additional work, or accept deductive alternates based on unit pricing or breakdown submitted herein. Bidders proposed Duration for Completion shall be for Total Base Bid.

Provide all labor, equipment, material, transportation, applicable tax, profit, insurance, bonds and overhead to perform the Work in accordance with the Project Plans and Technical Specifications. All items are Furnish and Install unless noted otherwise. Refer to Plans and Technical Specifications for more information.						
No.	Description	Reference	Unit Type	Unit Price	Unit Qty	Extension
1	General conditions/mobilization	General Conditions	--	--	--	
2	Supplemental conditions, including water quality and pathogen control requirements	Supplemental Conditions	--	--	--	
Pond RC-01						
3	3(a) Dewatering	Plans	Hour			
	3(b) Pond liner		Cubic yard			
	3(c) On-site soil disposal		Cubic yard			
	3(d) Turtle ramps (2)		Each			
	3(e) Staff gage (1)		Each			
Pond RC-07						
4	4(a) Grading/excavation	Plans	Cubic yard			
	4(b) On-site soil disposal		Cubic yard			
	4(c) Inlet/outlet pipes and rock armor		--	--	--	
	4(d) Staff gage (1)		Each			
Pond RC-10						
5	5(a) Grading/excavation	Plans	Cubic yard			
	5(b) On-site soil disposal		Cubic yard			
	5(c) Outlet pipe and rock armor		--	--	--	
	5(d) Turtle ramp (1)		Each			
	5(e) Staff gage (1)		Each			
6	Post-construction erosion control and seed broadcasting	Plans	--	--	--	
7	Stand down allowance	Plans	--	--	--	\$5,000
TOTAL BASE BID						
Proposed start date – pre-construction work: _____						
Proposed start date – on-site construction work: _____						
Total days to complete project: _____ Calendar Days						

2. UNIT PRICES

Unit Prices shall be used for delays incurred to the project due to special species conditions, and may be exercised at any time during the execution of the Work. Stand-down time eligible for reimbursement shall comply with Supplemental Conditions Article Four, paragraph J. Stand-Down Time.

No.	Description	Unit	Unit Price
U1	Stand-Down Time – Equipment Operator	Hour	\$
U2	Stand-Down Time – Forman	Hour	\$
U3	Stand-Down Time – Laborer	Hour	\$

3. ADDITIVE ALTERNATES

No.	Description	Reference	Add Amount
A1	Pond RC-07 existing fence removal	Construction Plans	
A2	Pond RC-01 fence/gate installation		
A3	Pond RC-07 fence/gate installation		
A4	Pond RC-10 fence/gate installation		

4. CURRENT WORKLOAD AND FINANCIAL CAPACITY.

Contractor must provide adequate current workload and financial information to confirm Contractor’s financial ability to deliver this project.

**(a)WORKLOAD – List ALL current Projects & Value of the Current Work Backlog:
(Attach additional pages if necessary)**

Project	Value of Unfinished Work	Percentage Complete

(b) FINANCIAL – List Contractors’ Company yearly gross revenue for the last three years:

i) List the Company’s yearly gross revenue for the past 3 years.

2022 _____ 2023 _____ 2024 _____

ii) List the Company’s net income for the past 3 years.

2022 _____ 2023 _____ 2024 _____

iii) List the Company’s amount of re-invested income for the past 3 years.

2022 _____ 2023 _____ 2024 _____

5. LITIGATION.

If additional space is needed for explanations, please attach additional pages as necessary.

a) Has your company been assessed liquidated damages within the past 5 years?

No _____ Yes _____

If Yes,

Where? _____

Why? _____

b) Has your company been terminated for default or cause within the past 5 years?

No _____ Yes _____

If Yes,

Where? _____

Why? _____

c) Are there any judgements, claims, arbitration proceedings, or suits pending or outstanding against your organization?

No _____ Yes _____

If Yes,

Where? _____

Why? _____

d) Has your organization filed any lawsuits, submitted claims, or been involved in any litigation with regard to your contract activity within the last five years

No _____ Yes _____

If Yes,
Where? _____

Why? _____

6. **EXPERIENCE.** List three recently (within last 5 years) completed jobs of comparable scope, the contract amount, names, and telephone numbers of contract officers. Use additional sheets as necessary. The selected projects must cumulatively demonstrate the Bidder's experience in **pond restoration** (grading, liner install, inlet/outlet pipe install, and/or erosion control) and working in job site(s) with **sensitive/listed species**.

Job/Project Name _____

Owner _____ Year _____ Contract Amt \$ _____

Contact _____ Phone _____

Project Description _____

Job/Project Name _____

Owner _____ Year _____ Contract Amt \$ _____

Contact _____ Phone _____

Project Description _____

Job/Project Name _____

Owner _____ Year _____ Contract Amt \$ _____

Contact _____ Phone _____

Project Description _____

-
5. **NONCOLLUSION CERTIFICATION.** The undersigned has executed and hereby submits the Noncollusion Affidavit (Form C.3), in accordance with Public Contracts Code Section 7106.

 6. **BID GUARANTEE.** No Bid will be considered unless accompanied by a guarantee in the amount of ten percent (10%) of the Total Base Bid), which shall be either a **BID BOND** (Attachment 4) written by an admitted surety satisfactory to the Authority in its sole discretion, a certified or cashier's check made payable to the Authority, or a cash deposit. In the event a successful bidder fails to satisfy all conditions for accepting the award (i.e. executed Agreement, provision of required bonds and proof of insurance) within the stated time limits, the Authority may declare the bidder's Bid Guarantee in default. Bidder acknowledges that the amount of actual damages the Authority would suffer in such event is extremely difficult and impractical to determine at this time by reason of the uncertainties, lapse of time, expense and loss of likely bidders resulting from the probable need to re-advertise and call for new bids. Bidder agrees that the amount of such Bid Guarantee shall be kept by the Authority as liquidated damages and agrees that the Authority may then award the work to any other bidder or may call for new bids. All Bid Guarantees will be held until after an award is made, an Agreement entered into, and required bonds and proof of insurance provided, at which time they will be returned.

7. **DISCLOSURE.** The names of all persons financially interested in this Bid Proposal are as follows:

Bidder, or any partner of Bidder, is a corporation, provide the legal name of the corporation, the state of its incorporation and the name and address of the President and of the Secretary. If Bidder is a partnership, provide name of the firm and names and addresses of all individual co-partners. Use additional sheets as necessary. If Bidder is an individual, provide the first and last name and address.

Name of Corporation: _____

State of Incorporation: _____

Name of Officer/Shareholder Title Address

Name of Bidder(s)/Partner(s) (If not a corporation)

8. **WITHDRAWAL OF BIDS.** Bids may be withdrawn prior to the opening of bids only by a signed, written notice received by the Authority Representative prior to the commencement of the bid opening. In consideration of Authority's reliance on and consideration of this Bid Proposal, the undersigned agrees that such Bid Proposal shall be irrevocable upon opening and shall not be withdrawn for sixty (60) calendar days following the bid opening even though award may be made to another bidder. Thereafter, such bid shall be automatically relieved.

I make the above Bid and declare under penalty of perjury that the statements made in this Bid Proposal are true and correct.

FULLY EXECUTED at _____,
City State

on _____,
Month Day Year

Signature¹ _____ Title _____

Name (please type or print) _____

Federal Employer I.D. Number _____

License Type _____

License Number _____ Expiration Date _____

DIR Registration Number _____

Name of Firm _____

Mailing Address _____

City _____ State _____ Zip _____

Phone (Bus) _____ Phone (Cell) _____

Email _____

¹ An authorized person for the Bidder must sign this Bid Proposal. If the Bidder is a partnership, a general partner must sign. If the Bidder is a corporation, an authorized officer of the corporation must sign and a corporate resolution conferring such authority must be provided.

C.2 LIST OF SUBCONTRACTORS
(To be executed by Bidder and Submitted with Bid)

Contractor must set forth the name, address, phone number, type and cost of work, and proof of required license for each subcontractor who will perform work or render services in any amount exceeding one-half percent (1/2%) of the total bid according to provisions of the California Public Contract Code §4100 through §4113. Each subcontractor must be licensed by the State of California Department of Consumer Affairs for the portion of work they perform in accordance with Contractor's License Law. Please attach as many sheets as necessary.

Company Name:

Contact:

Address:

Phone Number:

Type of Work:

Cost of Work:

Required License:

DIR Registration Number:

Company Name:

Contact:

Address:

Phone Number:

Type of Work:

Cost of Work:

Required License:

DIR Registration Number:

Company Name:

Contact:

Address:

Phone Number:

Type of Work:

Cost of Work:

Required License:

DIR Registration Number:

C.3 NONCOLLUSION AFFIDAVIT

NONCOLLUSION DECLARATION TO BE EXECUTED BY BIDDER AND SUBMITTED WITH BID

The undersigned declares:

I am the _____ of _____, the party making the foregoing bid.

The bid is not made in the interest of, or on behalf of, any undisclosed person, partnership, company, association, organization, or corporation. The bid is genuine and not collusive or sham. The bidder has not directly or indirectly induced or solicited any other bidder to put in a false or sham bid. The bidder has not directly or indirectly colluded, conspired, connived, or agreed with any bidder or anyone else to put in a sham bid, or to refrain from bidding. The bidder has not in any manner, directly or indirectly, sought by agreement, communication, or conference with anyone to fix the bid price of the bidder or any other bidder, or to fix any overhead, profit, or cost element of the bid price, or of that of any other bidder. All statements contained in the bid are true. The bidder has not, directly or indirectly, submitted his or her bid price or any breakdown thereof, or the contents thereof, or divulged information or data relative thereto, to any corporation, partnership, company association, organization, bid depository, or to any member or agent thereof to effectuate a collusive or sham bid, and has not paid, and will not pay, any person or entity for such purpose.

Any person executing this declaration on behalf of a bidder that is a corporation, partnership, joint venture, limited liability company, limited liability partnership, or any other entity, hereby represents that he or she has full power to execute, and does execute, this declaration on behalf of the bidder.

I declare under penalty of perjury under the laws of the State of California that the foregoing is true and correct and that this declaration is executed on _____, at _____, California.

(Page left intentionally blank)

C.4 BID BOND

(Note: Bidder must use this form if Bid Guarantee is a Bond)

KNOW ALL PERSONS BY THESE PRESENTS THAT [name of Bidder] (hereinafter Principal), as Principal, and [name of Surety], a corporation organized and doing business under and by virtue of the laws of the State of _____ and duly licensed for the purpose of making, guarantying or becoming sole surety upon bonds or undertakings required or authorized by the laws of the State of California, as Surety, are held and firmly bound unto the Santa Clara Valley Open Space Authority, a California Special Authority, (hereinafter called the Obligee) in the just and full sum of _____ Dollars (\$ _____) _____ lawful money of the United States of America, for the payment of which we hereby bind ourselves and each of our successors and assigns, jointly and severally, firmly by these presents.

THE CONDITION OF THIS OBLIGATION IS SUCH THAT, WHEREAS, the Principal is about to hand in to the Obligee a Bid for the project known as the Rancho Cañada del Oro Stock Pond Restoration Project in accordance with the Contract Documents filed in the office of the Obligee and under the notice inviting proposals therefor.

NOW, THEREFORE, if the Bid as submitted by said Principal shall be accepted, and the contract for such work or supplies be awarded to the Principal, and the said Principal shall fail, neglect or refuse to enter into a contract to perform said work or deliver said supplies, and furnish good and sufficient bond and proof of insurance therefore, then the amount of this bond shall be declared to be forfeited to the Obligee, Santa Clara Valley Open Space Authority.

IN WITNESS WHEREOF, Principal and Surety have caused these presents to be duly signed and sealed this _____ day of _____, 2025.

Signature of Principal Signature of Surety

Attorney-in-Fact
State of California,

County of _____)

On _____ before me, _____
(insert name and title of the officer)

personally appeared _____ who proved to me on the basis of satisfactory evidence to be the person(s) whose name(s) is/are subscribed to the within instrument and acknowledged to me that he/she/they executed the same in his/her/their authorized capacity(ies), and that by his/her/their signature(s) on the instrument the person(s), or the entity upon behalf of which the person(s) acted, executed the instrument.

I certify under PENALTY OF PERJURY under the laws of the State of California that the foregoing paragraph is true and correct.

WITNESS my hand and official seal.

Signature

Seal

(Page left intentionally blank)

C.5 PROOF OF PUBLIC WORKS CONTRACTOR REGISTRATION

Attach proof of Contractor and subcontractors' current and valid Department of Industrial Relations Public Works Contractor Registration (Lab. Code § 1725.5)

(Page left intentionally blank.)

